



Series  
NSX

SIZE 12 PC POST PIN CONTACT  
FRONT RELEASE FRONT REMOVABLE

Issue:  
5 MAY 99

Page  
1 / 1

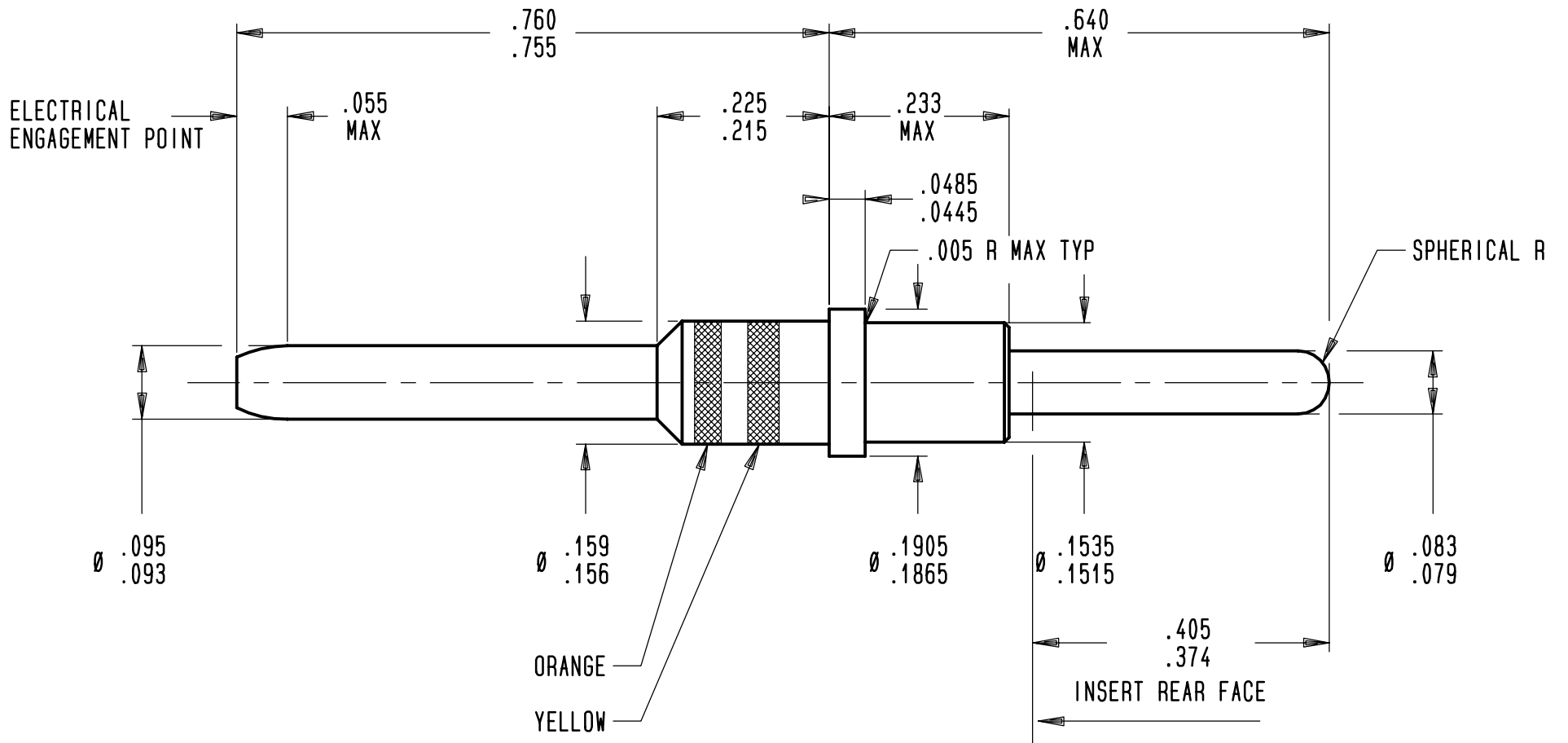

**MATERIAL AND FINISH**

BRASS PER ASTM B16M-85  
GOLD PER MIL G 45204 TYPE I OR II GRADE C OR D CLASS 1 OVER NICKEL UNDERPLATE  
PER QQ N 290 (50 TO 200 MICROINCHES)-PWB SOLDER CONTACT AREA WHICH IS TIN LEADED PER QQS 571 (.0025)

INSERTION / EXTRACTION TOOL :282 549 005

This information is given as an indication. In the continual goal to improve our products, we reserve the right to make any modifications judged necessary.

4112\_9311

CREATION				
PEN:94010 M94400002A				
NOM: MACARI	05/05/99	TOOL 282 549 005 WAS 282 504	MACARI	
DATE: 23 JUN.94	03/05/96	REDRAWN. ADDED PRECISIONS ON MATERIAL AND FINISH.	BALDYROU	VALGRESY
APPR.: DESPOUYIS	Issue	Revisions	Name	Approved